



ALBUQUERQUE PUBLIC SCHOOLS

Facility Design & Construction / Maintenance & Operations

Site Design Directives, Standard Specifications, and Standard Details for Site Design and Construction

Jerry Lee Ebner
Rick Leydig
Mario G. Juarez-Infante
Pat Westbrook
Elizabeth Calhoon

August, 2008

Albuquerque Public Schools

Landscape and Site Design Directives

Planting Design Directives

Planting Designs for all APS District Properties shall emphasize the use of Tree Plantings, both ornamental and shade, and large-scale shrubs. Ornamental shrub plantings should be avoided. Ornamental shrub plantings should be used sparingly and should be used to emphasize the primary building entrance. The reason for this directive is that the APS Grounds department is simply not able to maintain shrub beds and shrub plantings. The APS Grounds Department does not have the personnel required to perform weeding, deadheading, or chemical herbicide and pesticide applications that extensive ornamental shrub beds require.

The following items are required for all APS Planting Plans.

- All shade trees shall be a minimum 2.5” caliper, or larger.
- All ornamental trees (flowering pear, flowering plum, etc.) shall be a minimum 2” caliper, or larger.
- All shrubs shall be a minimum 5 gallon or larger.
- All shrubs shall be xeriscape plantings.
- All landscape areas are to be designed so that there is no site run-off of irrigation water.
- Tree wells located within paved areas shall have a minimum interior area of 10’x10’.
- The following Trees are shrubs shall not be planted on APS District Property:
 - Green and White Ashes
 - Elms (except Lace Bark Elms)
 - Hackberry
 - Kentucky Coffeetree
 - Black Locust
 - Sugar and Silver Maple
 - Poplars, Cottonwoods, and Aspen Trees
 - Spruces
 - Golden Raintree
 - Box Elder (except Sensation Maple)
 - Willows (except Desert Willow)
 - Russian Olives
 - Pyracantha
 - Ponderosa Pine
 - Pinon Pine
 - Sycamores
 - Oleander
 - Junipers
 - Cotoneasters

Euonymous

Mondell/Afgan Pines (Pinus Elderica) due to Pine Top Moths

- All landscape and irrigation projects shall be reviewed by a representative of Albuquerque Public Schools and shall include representatives of both Facilities Design and Construction and Grounds Department.
- All landscape areas shall receive aggregate mulches as a ground cover in the form of gravel mulches and/or crusher fines. Minimum depth of all gravel mulches shall be 2" depth and the minimum depth of all crusher fine mulches shall be 3" depth. All mulch areas shall receive filter fabric unless the mulch is crusher fines that are installed in a high traffic areas. The landscape architect shall consult with the APS Grounds Department to determine whether filter fabric is required or not. Organic mulches are not allowed on district properties except for the used of bark mulch rings at tree plantings.
- Aggregate mulch sizes shall be limited to the smallest size aggregate that is practical for each specific installation. Aggregate mulches larger than 1" size (for example: 2"-4" cobble) will not be allowed on APS district properties except for use on steep slope areas (3:1 and greater) and drainage areas. See the APS Drainage Design Directive Section for requirements in these areas. All aggregate mulches used on slope areas and drainage areas shall be a minimum 4" – 8" rip-rap material (or larger). All aggregate mulches used in drainage areas near buildings shall be embedded in concrete to prevent the stones from being dislodged. The design of sloped areas adjacent to or near buildings shall include the use of retaining walls, etc. to step grades and avoid the use of mulches on steep slopes. Crusher fines shall not be used in areas that are steeper than 10:1 and in areas that are to be used for conveying drainage or temporarily holding storm water run-off.
- All trees planted in turf areas shall receive a minimum of 2" depth and 6' diameter bark mulch ring at the base of each tree. The bark shall be kept back away from the trunk of the tree to prevent rotting.

Grass Sodding / Playfields and Athletic Fields

Grass sod shall be limited to use on playfields and athletic fields only.

Ornamental turf shall not be used on APS District properties.

- Sodded Turf shall be used on fields sized one (1) acre or greater. Any fields less than one acre shall be required to install artificial turf (see artificial turf design directives).
- Turf Grass species shall be limited to Bluegrass species mix unless otherwise prior approved by the APS Ground Department. (For Example: Blue Grass – Bermuda Grass Mix). Turf Grass species mixes such as "Park Blend" shall not be used on APS District

Properties. Turf grass species shall be noted on the construction drawings and shall not be included in the written specifications.

- Grass seeding shall not be used on playfields and athletic fields.
- All playfields and athletic fields shall be fenced with temporary construction fencing during the establishment period. The new playfield and athletic field will not be available for use by the school during the establishment period. The establishment period will be twelve months (one year) from the date of final acceptance. The cost of temporary construction fencing shall be paid for by APS through their on-call fencing contract and the costs of this fencing shall be included in the Landscape Architect's Opinion of Probable Construction Cost estimate for the project.
- All sodded turf areas and associated irrigation systems shall be designed so that there is **no off site run-off** of irrigation water.
- All sodded turf areas shall have full head to head coverage irrigation systems. (See Irrigation Design Directives)
- All sodded turf areas shall have a concrete mow curb consisting of a minimum 6" wide x 6" deep concrete mow curb around the entire edge of turf.
- A porous landscape buffer of ¼" minus crushed gravel shall separate all turf areas from all street curbs. The buffer shall be a minimum of 18" wide and 6" deep. The grass shall be separated from the buffer area with the required concrete mow curb. The top surface of the buffer shall be two inches below the top of the mow curb and two inches below the top of street curb.
- All turf playfields and athletic fields of one acre or greater shall have an irrigation system water audit performed prior to the installation of the sodded turf. A copy of the water audit shall be submitted to APS Grounds Department for review prior to installation of sodded turf. Any installed irrigation system that does not meet the minimum audit requirements shall be modified and a re-audit performed and approved prior to installation of sodded turf.

Ornamental Native Grass and Native Grass Re-Veg Seeding

- Native grass seeding shall not be used as an ornamental landscape treatment if the areas are irrigated adjacent to building and parking lot areas on APS District Properties (this also includes irrigated native grass areas). Native grass seeding areas can only be used as a landscape treatment for disturbed areas on the remote perimeters of the site. If permanent fencing is not in place around native grass seed areas, a temporary construction fence shall be required for any native grass seeded areas and this fencing shall remain in place for a period of no less than 12 months (one year) as an establishment period. The

cost for this temporary fencing shall be paid for by APS through their on-call fencing contract and the cost of this fencing shall be included in the Landscape Architect's Opinion of Probable Construction Cost estimate for the project.

- Landscape Designs shall only use native Grass Re-Veg Seeding in remote areas of a site that are not accessible to students.

Irrigation System Design Directives

- Prior to starting irrigation designs for any new or existing APS district property, Landscape Architects shall contact the APS Water Resource Specialist with APS Grounds Department to discuss the design scope, intent, equipment required, etc.
- All irrigation designs must be approved by the APS Water Resource Specialist prior to bidding or construction.
- The APS Water Resource Specialist must be represented at all preconstruction conferences and must be present for all required irrigation testing and for the final project walk-through meetings.
- The Landscape Architect shall provide the contractor with copies of the APS Irrigation Pressure Test Forms for use during all irrigation inspections. See attached forms.
- All irrigation plans shall meet the requirements of the City of Albuquerque Water Conservation Landscaping and Water Waste Ordinance and the Bernalillo County Water Conservation Ordinance.
- Whenever an irrigation plan involves modification to an existing irrigation system, the existing system shall be modified as necessary to bring the existing system into compliance with the City of Albuquerque and Plumbing Code requirements for backflow prevention.
- Irrigation Controllers shall be Motorola controllers. The specific type of controller and size of controller shall be as selected by the APS Water Resources Specialist. Controllers shall be placed in a fenced enclosure along with the backflow device. Irrigation controllers shall not be placed inside of buildings or inside walled enclosures.
- An irrigation audit shall be required for all high water use turf areas. High water use turf areas less than one acre are not allowed on APS District Properties.
- Irrigation systems shall be designed so that the system has the capacity to place 2 inches of water per week on high water use turf grasses. This water shall be applied in a five day period during a watering window from 10 pm to 7 am. (Twice a week will be used for mowing.)
- Each irrigation plan shall include a quick coupler valve to be installed at the lowest elevation possible on the irrigation mainline.

- To the extent practical, all irrigation systems shall have a separate water meter. In all cases, irrigation systems with high water turf areas or large planted areas shall have separate water meters.
- Reduced pressure backflow prevention devices installed in an insulated, heated hot box shall be used at all irrigation points of connection. The use of PVB's and AVB's will not be allowed on APS District Properties. Electrical service shall be extended to the hot box location. To the extent practical, Hot boxes and Irrigation controllers shall be installed in the same location and shall be placed inside a standard APS fenced enclosure. If electrical is not available the APS Water Resources Specialist shall decide on an alternative solution.
- All irrigation plans shall state the following information:
 1. Existing static pressure at meter or point of connection.
 2. Plans shall include a system performance chart that provides the following information for each control valve:
 - a. Control value number. Irrigation control valves shall be labeled numerically.
 - b. Valve Brand, and model number.
 - c. Irrigation head brand and model number.
 - d. Irrigation head nozzle size.
 - e. Irrigation head spacing.
 - f. Irrigation head gallons per minute.
 - g. Total gallons per minute for each valve and for total project.
 - h. Design operating pressure at the head.
 - i. Precipitation rate at design operating pressure.
 - j. Length of time required to operate valves in order to apply 0.33 inches of water.
- Whenever possible, systems shall use pressure regulating valves.
- The following statement shall appear on the face of each irrigation plan. "At the time of final acceptance, the Contractor shall demonstrate to the Landscape Architect and the Owner, that the operating pressure at each head has been adjusted to match the specified design operating pressure for each valve."
- Bubbler heads shall be low flow pressure compensating bubblers.
- **DRIP IRRIGATION SYSTEMS WILL NOT BE USED ON APS DISTRICT PROPERTIES.**
- Irrigation systems on slopes shall be designed so that heads at bottom of slope are on separate valves from heads on side and top of slope.

- Irrigation systems shall be designed so that there is no off site run-off of irrigation water.
- The APS Water Resources Specialist shall determine the selection of all irrigation product brands and models.

Section 32 80 00 Irrigation Systems

PART 1 GENERAL

1.01 SUMMARY:

- A. The work consists of installing a complete underground sprinkler system as shown on the Drawings and as specified hereafter. The Contractor performing this work shall furnish all labor, equipment, materials and permits necessary for the completion of the system, except those specified to be furnished by others. Unless otherwise specified or indicated on the Drawings, the construction of the sprinkler system shall include the furnishing, installing and testing of all pipe, fittings, valves, heads, controllers, wires, air release and vacuum valves, backflow preventers, inlet and discharge piping, manual drain valves, valve boxes, water meters, and all other components pertinent to the plans and specifications of this system. The Contractor shall perform all trenching, excavating, boring, backfilling, compacting, concrete pouring, electrical work, welding, and any other work necessary for the completion of the project.

1.02 SUBMITTALS:

- a. Prepare and make five sets of submittals providing manufacturer's specifications and "cut sheets" on all controllers, heads, backflow preventers, valves, pumps and other equipment as required.
- b. At Final Walkthrough: Contractor shall provide copies of checklist with dates and signatures of required tests and checks to Owner.
- c. Prior to laying sod or seed: provide a copy of passing water audit to Owner's representative.

1.03 RECORD DRAWINGS:

- A. The contractor shall provide and keep up to date complete set of "record" drawings which shall be corrected daily to show all changes in the location of sprinkler heads, controllers, backflow preventers, valves, drains, meters, points of connection, pull boxes and wire splice boxes, pipe and wire routing and other changes that may have been made from the original drawings and specifications as provided to him/her. All gate valves, manual drains, wire splice and automatic and manual valve locations shall be shown with actual measurements to reference points so they may be easily located in the field. Valve locations shall be

shown with actual measurements to reference points so they may be easily located in the field.

- B. At the time of final acceptance, the Contractor shall furnish a set of reproducible “record” drawings prepared by a qualified draftsman showing the entire complete system as actually installed. This is the responsibility of the Contractor and shall be accurate and to scale. The irrigation layout and legend shall be modified to designate any “record” changes. This “record” drawing shall be drawn on a project base sheet or AutoCAD base drawing provided by the Owner’s Representative. The final drawings shall be dated and clearly labeled “RECORD DRAWING”.
- C. The Contractor shall also provide and install in the controller enclosure at the project site, a legible reduction of the Record Drawing, laminated in plastic.

PART 2 PRODUCTS

2.01 MATERIALS:

- A. All materials shall be new and without flaws or defects of any type and shall be the best of their class and kind. All materials shall have a minimum guarantee of one year against materials defects or defective workmanship.
- B. All material shall be the brands and types notes on the Drawings or as specified herein or prior approved equivalent.
- C. The irrigation system was designed around equipment manufactured by specific companies as a standard. Approved equal equipment by other manufacturers may be used only with the approval of the Owner’s Representative and APS Water Resources Specialist. Request for approval of non-specified materials must be submitted to the Owner’s Representative a minimum of seven (7) days prior to opening of bids. Submission of irrigation sprinkler heads for approval as equal shall only be considered if submitted heads match the precipitation rate, gallons per minute and spacing of specified sprinkler heads.

2.01 PLASTIC PIPE AND FITTINGS:

- A. Plastic Pipe: All mainline pipe, from the point of connection to the zone valve, with a diameter of two inches (2”) or less shall be Schedule 40 PVC and shall conform to ASTM D 1785; mainline pipe with a diameter of two and one-half inches (2-1/2”) or greater shall be Class 200’ “O” ring gasket pipe, SDR 21; lateral line piping downstream of the zone valves which is 3/4” in diameter and greater shall be Schedule 40 PVC and shall conform to ASTM D 1785. Solvent shall meet ASTM L 2774 and D 2855 requirements. All PVC pipe shall be continuously marked with

identification of the manufacturer, type, class and size and shall be free of holes, foreign material, blisters, wrinkles, dents or sunburn.

- B. Location Tape: Irrigation line location tape shall be THOR Enterprises irrigation line marking tape.
- C. PVC Fittings: Fittings on PVC lines shall be Schedule 40 PVC, Type 1, Cell Classification 1345-B, and shall comply with ASTM D 2466.
- D. Threaded Nipples: All threaded PVC nipples shall be Schedule 80 Molded PVC pipe. All galvanized nipples shall be Schedule 40 galvanized steel pipe.

2.03 VALVES AND VALVE BOXES:

- A. Valves: Valves for use in electrically controlled automatic control systems shall be diaphragm actuated and hydraulically operated solenoid valves as specified on the Drawings.
- B. Valve Boxes: Valve boxes shall be as noted on the Drawings and as called for in the APS Standard Irrigation Details.

2.04 SPRINKLER HEADS AND BUBBLERS:

- A. Sprinkler heads and bubblers shall be as specified and installed as shown on the Drawings and as called for in the APS Standard Irrigation Details.

2.05 CONTROLLER

- A. Controllers shall be as specified on the Drawings and as called for in the APS Standard Irrigation Details. The exact controller type and size shall be approved by the APS Water Resources Specialist prior to ordering and installation.

2.06 BACKFLOW PREVENTER:

- A. The backflow prevention device shall be as specified on the Drawings and it shall comply with the City of Albuquerque Cross Connection Control Ordinance and the National Plumbing Code.

2.07 CEMENTS, CLEANERS/PRIMERS AND JOINT COMPOUNDS:

- A. Cement shall be #2200 series Uni-Weld or Rectorseal Cold low temperature plastic pipe cement for use on all sizes schedules of PVC pipe and fittings. Cement must be NSSF approved and meet ASTM D 2564 requirements.
- B. Cleaner/primer shall be #8700 United Elchem hi-etch cleaner/primer.

- C. All threaded connections between metal to metal, PVC to metal and PVC to PVC shall be made using RECTORSEAL #5 slow dry, soft set, thread sealing compound. Thread sealing compound shall not be used on threaded connections between sprinkler and nipple or bubbler and nipple.
- D. All "O" ring gasket and pipe spigot ends shall be lubricated using the lubricant recommended or supplied by the pipe manufacturer. If the pipe manufacturer does not provide a lubricant for the pipe, use IPS Weld-on #787 gasket lube as manufactured by Industrial Polychemical Service.

2.08 WIRE:

- A. Wire for the 120 Volt Wiring shall be solid copper (or stranded copper in larger wire sizes), underground feeder for direct burial and PVC insulated. Size of wire shall be #12 AWG.
- B. Wire for the 24 volt wiring shall be solid copper wire, PVC insulated; UL approved underground feeder wire for direct burial in ground. Common wires shall be #12, white, except as noted on Drawings. The wire shall be supplied in either 500' or 2,500' rolls. The control wires shall be #14 of any color other than white unless otherwise indicated on Drawings.
- C. Wire splicing Materials: All wire splices shall be made water-tight using 3M Scotchlok Connectors.

2.09 OTHER MISCELLANEOUS FITTINGS AND MATERIALS:

All other miscellaneous fittings and materials shall be specified on the Drawings.

PART 3 EXECUTION

3.01 GENERAL:

This section includes installation specifications for all items installed as part of the sprinkler irrigation system. Certain construction procedures or minor equipment installation procedures may have been omitted from these specifications that are necessary for the proper installation of the system. In any case, all materials and equipment shall be installed in a neat and workmanlike manner according to manufacturer's recommendations and specifications, local and state codes, as shown on the Drawings and as specified herein.

3.02 PRODUCT HANDLING:

The Contractor shall be responsible for correct procedures in loading, unloading, staking, transporting and handling all materials to be used in the system. The Contractor shall avoid rough handling which could affect the

useful life of equipment. Pipe shall be handled in accordance with the manufacturer's recommendations on loading, unloading and storage.

3.03 EXCAVATION AND TRENCHING:

- A. The Contractor shall stake out the location of each run of pipe and all sprinkler heads and valves prior to trenching. Each run of the system shall be approved by the Owner's Representative before actual installation is started.
- B. Excavation and trenching for pipe lines shall be true and line with the trench banks and as nearly vertical as practical. The width of the trenches shall not be greater than necessary to permit proper joining, tamping, backfilling, bedding or any other installation procedures that may be necessary. Trench widths shall also be wide enough so that there will be a minimum horizontal and vertical separation of 4" between pipes in the same trench.
- C. In areas where trees are present, trench lines will be adjusted on the site to eliminate any damage to tree roots.
- D. Trench depths shall be sufficient to provide the specified pipe cover as described elsewhere in these specifications or as noted on the Drawings. In rocky areas the trenching depth shall be 6" below normal trench depth to allow for pipe bedding as described in other portions of these specifications.
- E. Depth of bury: Minimum cover over mainline and lateral piping shall be as noted on the drawings.

3.04 PIPE AND FITTINGS INSTALLATION:

- A. Installation of plastic pipe and fittings shall be in accordance with the manufacturer's recommendations and procedures and as mentioned in the specifications. Manufacturer's recommended procedures for making solvent weld fittings shall be strictly adhered to. Only solvent cements, cleaners, and primers or lubricants recommended or supplied by the pipe manufacturer shall be used.
- B. Caution shall be exercised by the Contractor in handling, loading, unloading, and storing of PVC pipe and fittings. All PVC pipe shall be stored and transported in a vehicle with a bed long enough to allow the pipe to lie flat without subjecting it to undue bending or concentrated external load at any point. Any section of pipe that has been dented or damaged or in any other way found to be defective, either before or after laying shall be replaced with sound pipe without additional expense to the Owner.

- C. Before installation, the inside of the pipe shall be cleaned of all dirt and foreign matter and shall be kept in a clean condition during and after laying of pipe. When work is not in progress, open ends of pipe and fittings shall be securely closed so that no trench water, earth or other foreign substances will enter the pipe or fittings. Where pipe ends are left for future expansion or connections, they shall be valved and capped as directed on the irrigation system drawings.
- D. All PVC pipe and fittings shall be assembled to permit the pipe or fittings to be jointed at the true parallel position of the fittings. Placement of pipe in curving trenches which cause excessive bending and stress of pipe and fittings will not be permitted. No excess piping or fittings shall be permitted in the installation of the system, which may increase pressure loss or potential blockage.
- E. Before installing the pipe, all rubbish and large rocks shall be removed from the trenches. If the soil is extremely rocky, the trenches shall be bedded with dirt or sand as outlined in other portions of these specifications. Material used for pipe bedding shall be approved by the Owner's Representation. The full length of each section of the pipe shall rest solidly upon the pipe bed, with recesses excavated to accommodate bells, joints and couplings.
- F. Pipe shall not be laid in water or when trench or weather conditions are unsuitable for the work. Any water which may be encountered or may accumulate in the trenches or excavation shall be pumped out or otherwise removed as necessary to keep the bottom of the trench or excavation free and clear of water during the progress of the work. Pipe shall not be laid when the temperature is 32 degrees F or below.
- G. PVC pipe will expand or contract at the rate of 1" per 10 degree F change of temperature. Therefore, the pipe shall be installed in a manner so as to provide for expansion and contraction as recommended by the manufacturer.
- H. The minimum horizontal and vertical clearance between lines in the same trench shall be 4"
- I. After all sprinkler piping, risers, valves, thrust blocks, etc., have been installed and partially backfilled as specified in other parts of these specifications, the control valve shall be opened and a full head of water used to flush out the system. After the system is thoroughly flushed, risers shall be capped off and the system pressure tested in accordance with the testing section of these specifications. At the conclusion of the pressure test, the heads shall be installed and the backfill operation completed.

3.05 SOLVENT WELDING PROCEDURE:

- A. PVC plastic pipe shall be squarely cut utilizing a hacksaw with a blade of 18 or 24 teeth per inch.
- B. Burrs left from cutting shall be wiped off with a clean dry cloth.
- C. Utilizing a cleaner/primer, thoroughly clean the mating pipe end and the fitting socket with a clean dry cloth.
- D. Apply a uniform coat of solvent cement to the outside of the pipe end with a non-synthetic brush or dauber.
- E. In like manner, apply a thin coating of solvent cement to the inside of the fitting socket.
- F. Re-apply a light coat of solvent cement to the pipe end and quickly insert it into the fitting to the full depth of the fitting socket.
- G. Rotate the pipe or fitting approximately $\frac{1}{4}$ turn to insure even distribution of the solvent cement.
- H. Hold in position for approximately 30 seconds.
- I. Wipe off any excess solvent cement that forms as a bead around the outer shoulder.
- J. Care should be taken so as not to use an excess amount of solvent cement that could cause burrs or obstructions to form on the inside of the pipe joint.
- K. Solvent weld joints shall be allowed to cure for at least 24 hours before pressure is applied to the system.

3.06 BACKFILLING:

- A. Upon completion of a particular section of the irrigation system, and after sufficient time has elapsed for the curing of solvent weld joints, partial backfilling can begin, leaving all joints, risers and connections exposed for visual inspection during the hydrostatic testing. Only upon successful completion of the hydrostatic test can the backfill operation be completed for any one particular section.
- B. All backfill material shall be subject to approval by the Owner's Representative. Backfill material shall be free from rock, large stones, brush, sod, frozen material or other unsuitable substances that may damage pipe during the backfilling operations.

- C. In the event that the material from the excavation or trenching is found to be unsuitable for use in backfill by the Owner's Representative, it shall be removed from the site and properly disposed of by the Contractor and at his own expense. The Contractor shall then, at no additional cost to the Owner, arrange for, purchase, and furnish suitable backfill material consisting of earth, loam, sandy clay, sand or other approved materials free of large clods of earth or sharp stones and capable of attaining the same relative density of the surrounding ground.
- D. In rocky areas, the trench depth shall be 6" below the normal trench depth to allow for 6" of suitable backfill as padding for the pipe. In like manner, there shall be at least 6" of padding on all sides of the pipe as a padding against the rock wall of the trench.
- E. All mainline and lateral piping shall have irrigation line location tape installed in the trench six (6") above the pipe.
- F. Backfill shall be placed in horizontal layers not exceeding 6" in depth and shall be thoroughly tamped, or water compacted to near original density or so that no settling will result. Backfill shall be placed to the original ground level. If settlement of trenches occurs within one (1) year from date of completion, it shall be the Contractor's responsibility to refill trenches and re-seed or sod the repaired areas.

3.07 SADDLE TAPS:

- A. No saddle taps shall be permitted unless approved by the Owner's Representative.

3.08 THRUST BLOCKS:

- A. Concrete thrust blocks shall be provided where necessary to resist system pressure. Thrust blocks shall be constructed at all direction changes, size changes, valves and terminations or at any other points of the systems that will result in an unbalanced thrust line for equipment 2-1/2" and larger. Do not obstruct outlets of fittings which are intended for future connections. Thrust blocks shall be poured against undisturbed earth and in accordance with the APS Standard Details.

3.09 SLEEVED CROSSING:

- A. Unless otherwise noted on plans, all piping installed under sidewalks, roadways, parking lots, paved areas, etc. shall be sleeved in Class 200 PVC pipe two (2) sizes larger than the pipe to be sleeved. Wiring shall be placed in a separate sleeve from that of the pipe crossing and shall be a minimum 1 1/4" Class 200 PVC. Ends at sleeves shall be sealed with duct tape following installation of wire or piping. A marker consisting of a piece of scrap PVC pipe painted bright orange shall be

placed so that one end extends just above finished grade at each end of the sleeve marking location for future use.

3.10 SPRINKLER HEAD INSTALLATION:

- A. Sprinkler heads shall be of the type and make specified and shall be installed as shown on the Drawings and per APS Standard Details. Sprinkler heads shall be installed with a 4" space between the edge of the sprinkler head and curbs, walls, driveways, building wall, etc. Heads shall be installed in the vertical position and backfilled and compacted to near original density.
- B. Sprinkler head spacing shall not exceed the spacing shown and shall be in the location and configuration as shown on the Drawings. Contractor shall verify turf area dimension while staking sprinkler head location. Sprinkler heads shall be spaced to achieve uniform coverage. If the spacing shown on the Drawings differs from the spacing needed to achieve uniform coverage in the field, uniform coverage in the field will take precedence over location shown on the drawing. The location of sprinkler heads shall be flagged / staked in the field and the location shall be approved by the APS Water Resources Specialist and the Owner's Representative prior to installation.
- C. After all piping and risers are in place and connected and before installation of the sprinkler heads, all control valves for a given section shall be fully opened and a full head of water shall be used to flush out the system. If water pressure without the heads installed is not sufficient to provide adequate water flow from end risers, the Contractor shall cap off enough heads closest to the water source to provide adequate flushing to the end riser assemblies.

3.11 CONTROLLER INSTALLATION:

- A. The controller location is indicated on the Drawings. The Contractor shall familiarize himself with the requirements of making the power connections at the locations noted (120 volt supply to the Controller) and shall include the cost to complete this portion of the contract in his price to the Owner unless otherwise directed by the Owner's representative.
- B. The Controller shall be mounted and wired according to the manufacturer's recommended procedures and as specified herein and on the Drawings.
- C. For Controllers installed inside of vaults or other enclosures, the Contractor shall provide and install on the Controller an electrical pigtail outlet and a Tass and Seymour pilot switch and receptacle 15AC1-RPL.

- D. When Controllers are mounted outside of any building, vault, or enclosure, the Contractor shall direct wire the 120 volt power supply to the Controller.
- E. Remote control valves shall be connected to Controller in the numerical sequences as shown on the Drawings or as directed by the Owner's Representative.

3.12 AUTOMATIC CONTROL VALVE INSTALLATION:

- A. All automatic control valves shall be of the type and size as indicated on the Drawings. Installation shall be according to these specifications, the Drawings and the manufacturer's recommendations.
- B. The valve boxes shall be of the size and type as shown in the details drawings.
- C. Valve wire splices shall be waterproofed using 3M Scotchlok Connectors and the Contractor shall provide a 36" wire expansion coil to facilitate raising splices to ground level without cutting wires.

3.13 24 VOLT CONTROL VALVE WIRING:

- A. All wire installation procedures as described herein shall be checked to conform to local codes.
- B. The Contractor shall install the 24 volt control valve wiring in the same trench as the irrigation mainline. Only when it is not possible for the wires to be installed in the mainline trench, they shall be installed in the lateral pipe trench. All wires shall be laid below the pipe. In no case shall the wire be laid on top of the pipe. The wires shall be laid loose in the trench and taped together at 10'-0" intervals. When trenches used for piping are not appropriate for routing wire, Contractor shall install wire in a separate trench, 18" deep.
- C. Wire splices, other than at valve box locations shall be kept to a minimum and if needed shall be made only at common splice points and placed in a wire splice box as shown in the detail drawings and in the APS standard drawings. The location of these wire splice boxes shall be made waterproof using 3M Scotchlok connectors.
- D. At control wire splices, the Contractor shall provide a 36" wire expansion coil to facilitate raising splices to ground level without cutting wires.
- E. All continual wire shall be one color and in no case shall wires of different colors be spliced together.

- F. All 24 volt wiring shall be installed in PVC conduit when inside a building. All 24 volt wiring installed on exterior building walls shall be installed in metal conduit.

3.14 120 VOLT CONTROLLER POWER WIRING:

- A. The Contractor shall familiarize himself with the work required to complete this portion of the installation. All 120 volt wiring shall be installed in accordance with local electric codes. The 120 volt service shall consist of one (1) black and one (1) white wire. The neutral wire shall be bonded.
- B. 120 volt power shall be supplied to the Controller location by a licensed electrician.

3.15 MANUAL DRAIN VALVES:

- A. Manual drain valves shall be of the size and type as indicated and at the locations as shown on the Drawings or as approved by the Owner's Representative.

3.16 TESTNG:

- A. Upon completion of the irrigation systems mainline, the entire mainline shall be tested for a one hour period at 100 psi, unless otherwise notes. Prior to testing, the mainline shall be partially backfilled, leaving all joints and connections exposed for visual inspection. All dirt shall be flushed from the system and the line filled with water to remove air. The mainline shall be brought to static pressure. A pressure gauge and temporary valve shall be installed at the end of the mainline to permit air pressure to be applied to the main. A pressure of 100 psi must be retained for a one hour period. Any leaks resulting in the one hour pressure test shall be repaired and the system retested until the system passes the test.
- B. Upon completion of the lateral piping sections, each lateral system shall be pressure tested for one hour at 100 psi. On systems using flex nipples, or swing joints, the lateral system shall be tested prior to installation of the flex nipples or swing joints. Prior to testing the lateral lines shall be partially backfilled leaving all joints and connections exposed for visual inspection. All air and dirt shall be flushed from the system and all open fittings shall be capped. The testing procedure shall be the same as used for the mainline. If after one hour no visual leakage has occurred and the 100 psi pressure has been retained, the heads shall be installed, and the backfill operation completed. Any leaks resulting from the hydrostatic test shall be repaired and the system retested until the system passes the test.

3.17 ADJUSTING OF SYSTEM:

- A. After completion of testing and installation, the Contractor shall adjust all valves for the proper operating pressure and adjust all sprinklers and bubblers for uniform coverage and even flow. Contractor shall wire the Controller (valve/station) as directed by the APS Water Resource Specialist or the Owners Representative. The valve number will be indicated on the Controller panel for each station. Contractor will program Controller to provide optimum sprinkler system performance.

3.18 IRRIGATION AUDIT:

- A. If the turf area being watered by the irrigation system has a total area of one or more acres, the Contractor must have a Landscape Irrigation Audit performed as required by the City of Albuquerque Water Conservation Landscaping and Water Waste Ordinance and the Bernalillo County Water Conservation Ordinance. The audit must be performed prior to the installation of sodded turf or seed. The system must be adjusted to meet the required minimum efficiency requirements prior to installation of the turf or seed.

3.19 CLEAN UP:

- A. The Contractor shall continuously keep a neat and orderly area in which he is installing the system. Disposal of rubbish and waste material resulting from the installation shall be continual. Upon completion of the system, the Contractor shall remove from the Owner's property at his own expense, all temporary structures, rubbish waste material, tools and equipment resulting from or used in the installation of the system.

3.20 PROTECTION OF EXISTING UTILITIES:

- A. The Contractor shall be responsible for locating all cables, conduits, piping, and any other utilities or structures that may be encountered either above or below ground. All necessary precautions must be taken by the Contractor to prevent any damage to these existing utilities and improvements. In the event that such damage should occur from his operations, the Contractor shall repair or replace damaged utilities to their original condition at no additional expense to the Owner.

3.21 ROCK:

- A. If the Contractor encounters rock or other unfavorable trenching conditions, no additional compensation will be paid. When material from the excavation or trenching is unsuitable for use as backfill, additional backfill material suitable for this purpose shall be brought in at the expense of the Contractor. It shall be of the Contractor's responsibility to remove and dispose of all unsuitable materials removed from the trench that cannot be used in the backfill operation.

3.22 FINAL ACCEPTANCE:

- A. When the Contractor is satisfied that the system is operating properly, that it is balanced and adjusted, that all work and clean-up is completed he shall issue notice of completion to the Owner's Representative requesting a final inspection. The Owner's Representative will respond to the notice of completion by the Contractor and shall appear with the Owner's representatives from Facilities Design and Construction and Maintenance and Operations for an inspection of the project. At that time the Contractor shall demonstrate the operation of each system in its entirety. In judging the work, no allowance for deviation from the Original Drawings and Specifications will be made unless prior approval from the Owner's representative has been obtained.
- B. Any inconsistency to the Specifications or the Drawings shall be noted by the Owners Representative and a written copy of required corrections shall be given to the Contractor. Any work deemed not acceptable shall be re-worked to the complete satisfaction of the Owner's Representative.
- C. When the completed work and the "IRRIGATION RECORD DRAWINGS", certification of backflow inspection, keys and maintenance manual have been reviewed and approved by the Owner's Representative, a written acceptance of the project signed by the Owner's Representative will be given to the Contractor.

3.23 OPERATIONAL INSTRUCTION:

- A. After the system has been tested and accepted, the Contractor along with the Owner's Representative shall instruct the representative of APS M&O in the operation and maintenance of the system.
- B. The Contractor shall provide the Owner's Representative with two (2) keys for the following:
 - 1. Controllers
 - 2. Any Locking Assembly in need of keyed access.
- C. The Contractor shall provide the Owner with two copies of a Maintenance Manual bound in a three ring binder. The maintenance manual shall include copies of the approved submittals, Controller operations manuals and manufacturer's warranties on all irrigation products.

3.24 SYSTEM MAINENANCE AND GUARANTEE:

- A. For a period of one (1) year from final acceptance of the system, the Contractor will promptly furnish and install, without cost to Owner, any and all parts or materials which prove defective in material or workmanship. Damage due to irrigation system line breaks shall be

repaired and brought to original condition by the Contractor at no expense to the Owner.

- B. For a period of one (1) year from final acceptance of the system, the Contractor shall repair any settlement of trenches by one of the following methods as directed by the Owner's Representative.
 - 1. Bring to grade by top-dressing (raking topsoil into the grass)
 - 2. Bring to grade with topsoil and seed.
 - 3. Remove existing sod, fill depression with topsoil, and replace with new sod to match existing sod.
 - 4. Repair by any of the above methods must result in a smooth, level area. Maintenance of repaired areas shall be the responsibility of the Owner.

3.24 INSPECTION:

- A. The following inspections shall be the minimum required inspections during the course of construction. Additional inspections shall be made at any time at the discretion of the Owner's representative. It shall be the responsibility of the Contractor to notify the Owner's Representative, in writing, 24 hours in advance of each required inspection. The sequence of required inspections shall not be changes from the sequence listed below. The Contractor shall not proceed with work of the next sequence without written approval of the work of the previous sequence. The Contractor shall attach a copy of the written inspection approvals to all applications for payment.
 - 1. Inspect staked/flagged locations of mainline, valves, laterals and sprinkler heads.
 - 2. Inspect and pressure test mainline installation.
 - 3. Inspect 24 volt control wire installation.
 - 4. Inspect and pressure test automatic valves and lateral irrigation installation.
 - 5. Inspect automatic controller installation and operation.
 - 6. Inspect sprinkler and bubbler head placement, coverage and operating pressure prior to planting.
 - 7. Inspect at end of maintenance period.

END OF SECTION 32 80 00

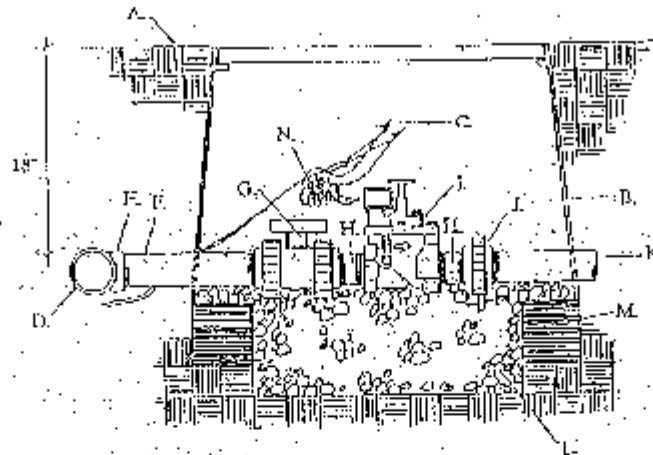

GENERAL NOTES

1. Install an 8" x 8" x 16" solid CMU block at each corner of the valve box.
2. Wash rock shall be installed flush with bottom of pipe and valve.

CONSTRUCTION NOTES

- A. Finish grade.
- B. Brooks Products Inc., 1730 PB-18 Body (AHS) valve box with 1730 Bolt Down Cover (AHS) and one 8" extension.
- C. IM Scotchlok connection.
- D. Irrigation mainline.
- E. Irrigation mainline service tee or ell.
- F. Schedule 80 PVC x 1 1/2" nipple.
- G. Spears True Union Schedule 80 PVC Ball Valve.
- H. Schedule 80 PVC close nipple.
- I. Electric Valve (Reference the Drawing).
- J. Spears Schedule 80 PVC Union.
- K. Lateral pipe.
- L. 1 cubic foot 1" diameter washed rock.
- M. 8" x 8" x 16" solid CMU block.
- N. 24" wire expansion coil.



ELECTRIC VALVE



Albuquerque Public Schools
January, 1995

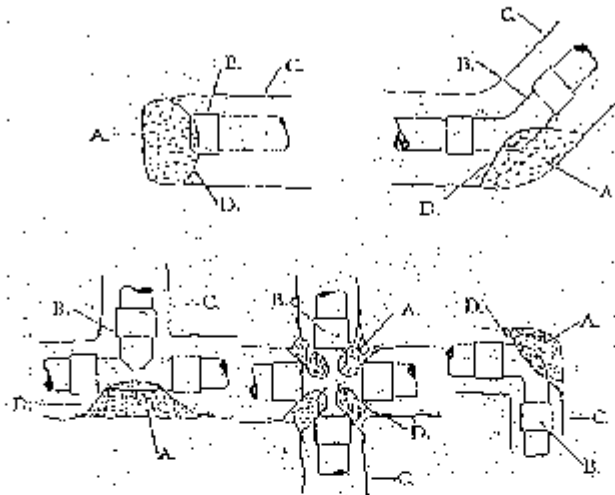

GENERAL NOTES

1. PVC fittings shall be protected from concrete by placing 10 mil plastic sheeting between concrete and fitting.

CONSTRUCTION NOTES

- A. Concrete thrust block placed against soft undisturbed soil.
- B. PVC fitting.
- C. Pipe trench.
- D. 10 mil plastic sheeting.



THRUST BLOCKS



Architectural Design Services
January, 1995

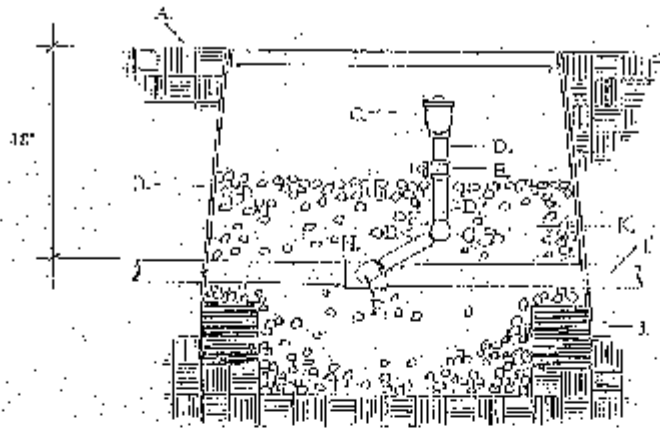

GENERAL NOTES

1. Install an 8' x 8' x 16' solid CMU block in each corner of the valve box.
2. Wash rock shall be installed flush with bottom of gate valve.
3. Air release valve shall be installed downstream of the master valve.

CONSTRUCTION NOTES

- A. Finish grade.
- B. Brooks Products Inc., 1730 PSI 18 body (ABS) valve box with 1730 Bolt Down Cover (ABS) and one 8" expansion.
- C. Air release valve (reference the Drawing).
- D. Schedule 90 PVC nipple.
- E. Gate valve.
- F. Schedule 40 PVC 3/4" ell.
- G. Schedule 40 PVC 90° ell.
- H. Irrigation mainline tee.
- I. Irrigation mainline.
- J. 8' x 8' x 16' solid CMU block.
- K. 1 cubic foot 1" diameter washed rock.



AIR RELEASE VALVE



Albany Area Public Schools
January, 1995

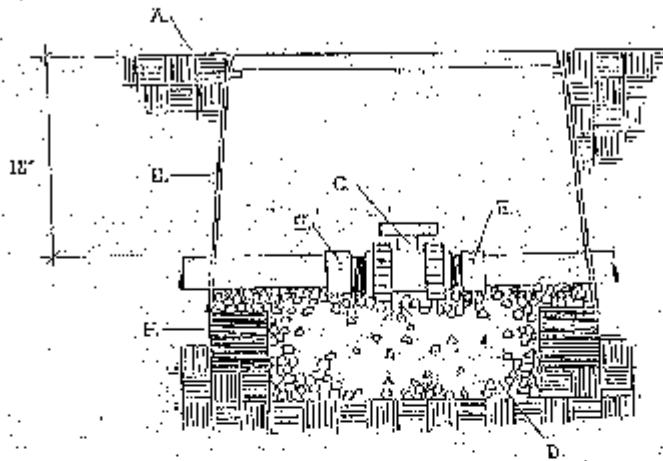

GENERAL NOTES

1. Install on 8" x 8" x 16" solid CMU block at each corner of the valve box.
2. Washwork shall be installed flush with bottom of pipe and valve.

CONSTRUCTION NOTES

- A. Finish grade.
- B. Brooks Products, Inc., 1730 P13 18 Body (ABS) valve box with 1730 Float Down Cover (ABS) and 1/2" x 8" extension.
- C. Spears True Union Ball Valve.
- D. 1 cubic foot 1" diameter washed rock.
- E. PVC MIP adapter.
- F. 8" x 8" x 16" solid CMU block.



ISOLATION VALVE



Albuquerque Public Schools
January, 1995

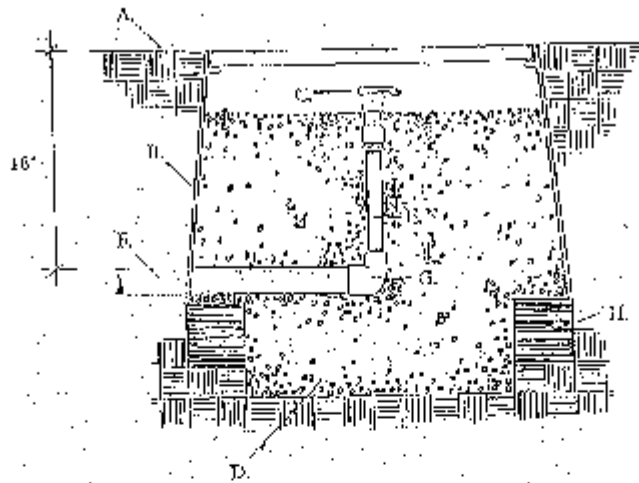

GENERAL NOTES

1. Install an 8" x 8" x 16" solid CMU block at each corner of the valve box.
2. Install 1 cubic foot of 1" diameter washed rock below the valve box. Extend washed rock up to collar of quick coupler valve.
3. Install an isolation valve immediately upstream of quick coupler valve. (Reference isolation valve detail).

CONSTRUCTION NOTES

- A. Finish grade.
- B. Frigida Products, Inc. 1730 PB-18 Body (ABS) valve box with 1730 Bolt Down Cover (ABS) and one 8" extension.
- C. RainBird 22 DR-2 quick coupling valve.
- D. 1" diameter washed rock.
- E. 12" schedule 80 PVC riser.
- F. Irrigation manifold.
- G. Schedule 40 PVC cap 30".
- H. 8" x 8" x 16" solid CMU block.



QUICK COUPLER VALVE



Albuquerque Public Schools
January, 1995

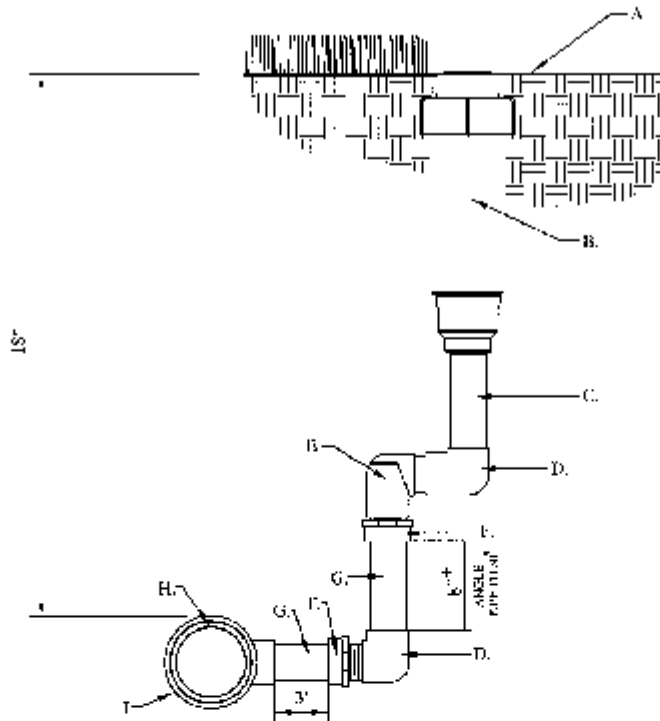

GENERAL NOTES

1. Swing joint assembly shall be Lazen, manufactured by Phillips Industries, Inc., Denver, CO, Dallas, TX, et al.
2. All glue fittings shall be assembled and dry prior to assembly of threaded fittings.
3. No teflon tape or pipe dope shall be used.
4. All threaded fittings shall be hand tightened only and then loosened one full turn prior to installation in trench.
5. Lateral line pressure testing shall be completed prior to installation of swing joint assembly. Lateral line testing shall be accomplished by installing caps at the first male adapters down stream of the tee and ell's.
6. Top of sprinkler head shall be set flush with the finish grade.

CONSTRUCTION NOTES

- A. Finish Grade
- B. Sprinkler Head (Reference the drawings)
- C. Sch 80 PVC Tee (rippe). Size length as required
- D. 90° elbow with Acme threads
- E. 90° street ell with Acme threads
- F. Male adapter with Acme threads
- G. Sch 40 PVC pipe
- H. Sch 40 PVC ExS&T tee or ExT ell
- I. Lateral Pipe



ROTOR SPRINKLER HEAD W/SWING JOINT ASSEMBLY
(ATHLETIC FIELDS & LARGE TURF AREAS)



Athletic Fields & Large Turf Areas
 02/2014

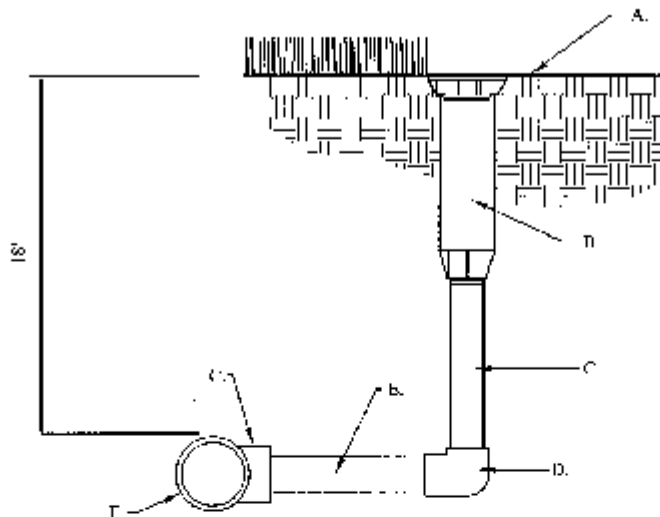

GENERAL NOTES

1. Lateral line pressure testing shall be completed prior to installation of this pipe assembly. Lateral line testing shall be accomplished by installing a plug in the outlet of lateral line tees and ells.
2. Top of sprinkler head shall be set flush with the finish grade.

CONSTRUCTION NOTES

- A. Finish Grade
- B. Sprinkler Head. (Reference the drawings).
- C. Sch 80 PVC tee nipple. Length varies depending upon size of sprinkler head.
- D. Sch 40 PVC threaded ell.
- E. Sch 80 PVC nipple, 12".
- F. Lateral Pipe
- G. Sch 40 PVC SxSxT tee or SxT ell.



SPRINKLER HEAD (POP-UP ASSEMBLY)



Albuquerque Public Schools
July 2008

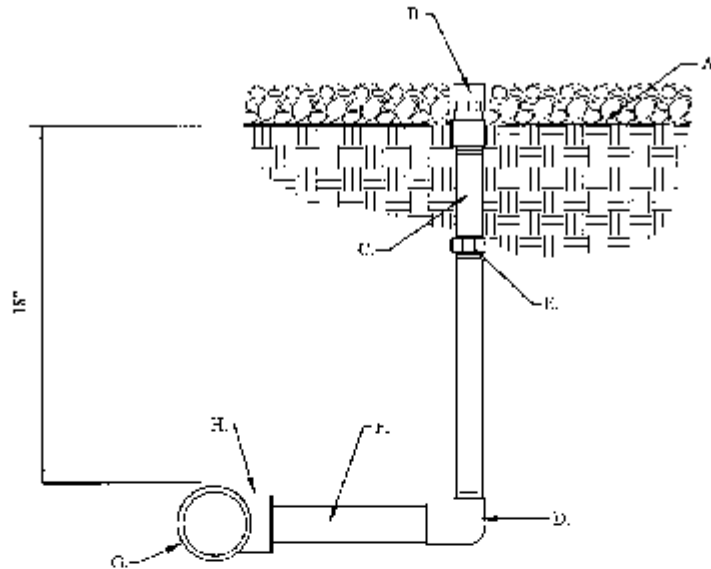

GENERAL NOTES

1. Lateral line pressure testing shall be completed prior to installation of flex pipe assembly. Lateral line testing shall be accomplished by installing a plug in the center of lateral line to seal end of s.
2. When bubblers are used to water shrubs, there shall be one bubbler installed on the uphill side of each shrub. The bubbler shall be installed 8" from the edge of the root ball.
3. When bubblers are used to water trees, there shall be one bubbler installed on the uphill side of each tree. The bubbler shall be installed 12" from the edge of the root ball.

CONSTRUCTION NOTES

- A. Finish Grade.
- B. Bubbler head. (Reference the drawings). Top of bubbler shall be flush with top of mulch.
- C. Sub 80 PVC nipple.
- D. Sch 40 PVC threaded ell.
- E. Sch 80 PVC threaded coupler.
- F. Sch 80 PVC nipple, 12"
- G. Lateral pipe.
- H. Sch 40 PVC 8x8xT w/c or 8xT ell.



BUBBLER HEAD ASSEMBLY



Adapted from the Standard
to 2001

Section 32 92 00
Grass Sodding

PART 1 GENERAL

1.01 SUMMARY:

- A. Work under this section consists of preparing all areas indicated on the drawings for grass sodding according to the specifications including furnishing and installing all sod, fertilizer and soil amendments as specified herein.

1.02 REFERENCE STANDARDS:

- A. ASPA (American Sod Producers Association) – Guideline Specifications to Sodding.

PART 2 PRODUCTS

2.01 SOD MATERIAL:

- A. Grass Sod: Sod shall be as specified in the APS Design Directives. A sample of sod and a written submittal of the seed mix shall be submitted a minimum of fifteen (15) days prior to laying of sod. It shall be vigorous, well rooted healthy turf free from disease, insect pests, weeds, other grasses, stones and other harmful or deleterious matter.
- B. Sod shall be cut by an approved mechanical sod cutter to a thickness of not more than 1" or less than ½". Sod pieces shall be cut a maximum of 18" wide. Handling of sod shall be done in a manner that will prevent tearing, breaking, dying or any other damage. Sod shall be installed in place on the site not more than 24 hours after cutting.
- C. Sod shall have no more than ½" of loose thatch. The sod shall be dense enough so that an entire strip can be lifted by the top 10% without breaking.
- D. Large rolls of sod will be used for large areas.

2.02 FERTILIZER:

Organic amendment shall consist of:

- A. 70% by volume, organic compost. Compost to be screened to ½" minus, pH not to exceed 7.0. Electrical conductivity (EC) of compost not to exceed 3.5 mnhos/cm. Percentage of organic matter shall be not less than 1% by weight. Carbon to nitrogen ratio of compost shall not exceed 50:1.
- B. 10% by volume, "Ecolite" (clinoptilotite zeolite). Ecolite shall be screened to pass a #40 mesh screen.

- C. 20% by volume, Moisturelite”, screened to pass a #40 mesh.
- D. Components to be homogeneously mixed, in ten cubic yards batches to provide a uniform product, free from weed seeds, sticks, rocks, or other deleterious material.
- E. The organic amendment shall be as produced by:
 Growell,
 RR9, Box 862, 2nd and Bates Rd., SW
 Albuquerque, NM 87105
 (505)877-8670
 Or equal.
- F. Each delivery shall have a load ticket. The load ticket shall list:
 Source of Material
 Approximate Volume of Load
 Date of Delivery of loading
 Name of Individual representing the source.

Ticket shall be collected and provided to the Owner’s representative.

PART 3 EXECUTION

3.01 SOD BED PREPARATION:

- A. Prior to start of soil preparation all finish grades shall be established and approved as meeting the requirements of the grading plan.
- B. Apply a uniform 2” layer of organic amendment and 4lbs. of starter fertilizer per each 1000 square feet to the entire area to be sodded. After application of organic amendment and starter fertilizer all areas to be sodded shall be ripped to a depth of twelve inches and thoroughly rototilled to a minimum depth of 6 inches. Owner’s representative prior to laying sod shall check the depth of Ripping and rototilling. After rototilling in complete at cross directions, drag to an even grade, then roll for firmness.

3.02 SODDING:

A. INSTALLATION:

1. Before laying sod, the finish grade shall be brought to a firm, even surface, free from stones or lumps, and shaped to provide drainage. The finish grade shall be inspected and approved by the Owner’s Representative prior to laying any sod.
2. Lay sod over moistened soil lightly raking the soil ahead of each sod strip. Sod shall be fitted together tightly so that no joint is

visible, and sod tamped firmly and evenly by hand. Stake as required on slopes.

3. Water all sodded areas immediately after final rolling with a fine spray to a depth of 4". Irrigation by means of the automatic underground irrigation system all sodded areas as often as necessary to promote healthy grass growth. Mowing during the maintenance period will be scheduled so that the grass is maintained at a height no shorter than two (2) inches and no greater than three (3) inches.

3.04 MAINTENANCE AND PROTECTION:

- A. Maintenance and protection shall continue for thirty (30) days, or until the entire landscape project is accepted. Acceptance shall only occur after all sod is well rooted.

3.05 INSPECTIONS:

- A. The following inspections shall be the minimum required inspections during the course of construction. Additional inspections during the course of construction. Addition inspections shall be made at any time at the discretion of the Owner's Representative.
- B. It shall be the responsibility of the Contractor to notify the Owner's Representative, in writing, 48 hours in advance of each required inspection.
- C. The sequence of required inspections shall not be changed from the sequence listed below. The Contractor shall not proceed with work of the next sequence without written approval of work of the previous sequence. The Contractor shall attach a copy of the written inspection approvals to all applications for payment. Payment will not be approved for items which have not been inspected and approved in writing.
 1. Automatic irrigation system shall be installed, tested, and approved. Turf spray head layout shall be approved prior to installation. Turf spray system shall be audited and a passing audit shall be reviewed and approved by the Owner's Representative and the APS Water Resources Specialist prior to installation of sod.
 3. Each phase of soil preparation shall be inspected in process.
 4. Owner's representative shall inspect the depth of ripping and rototilling during the soil preparation phase.
 5. Final grade shall be inspected.

6. Sod shall be inspected prior to laying.
7. Sod shall be inspected after completion.
8. Sod shall be inspected at the end of 30 day maintenance period.
9. Sod shall be inspected 6 months after completion.
10. Sod shall be inspected 12 months after completion.

3.06 GUARANTEE:

- A. All sod shall be guaranteed to be in alive, healthy, and normal growing condition following the date of final acceptance by the Owner's Representative through one twelve month growing season. Sod that is dead or in an unhealthy, impaired growth condition, shall be removed and replaced by the Contractor as directed by the Owner's Representative at no additional cost to the Owner.

END OF SECTION 32 92 00

Section 32 93 00
Landscape Planting

PART 1 GENERAL

1.01 SUMMARY:

- A. Work under this section consists of the planting of trees, shrubs, and ground covers, including the furnishing of all labor, equipment, accordance with the Drawings and Specifications.

1.02 PLANT NAMES:

- A. The botanic and common names used for the plants called for on the Drawings are generally in conformity with the approved names given in Standardized Plant Names, 1980 Edition, published by the American Joint Committee on Horticultural Nomenclature. The names of varieties not included therein are generally in conformity with the names accepted in the nursery trade.

1.03 PLANT MATERIAL SUBSTITUTIONS:

- A. Plant material substitutions shall not be made without written permission of the Owner's Representative. The use of materials differing in kind, quality or size from the specified will be allowed only after the Owner's Representative is convinced that all means of obtaining the specified materials have been exhausted. At the time bids are submitted, the Contractor is assumed to have located the materials necessary to complete the job as specified.

PART 2 PRODUCTS

2.01 PLANT MATERIALS

- A. A complete plant list, including quantities, sizes and other requirements is shown on the Drawings. In the event that discrepancies occur between quantities of plants indicated in the plant list and on the Drawings, the plant quantities indicated on the Drawings shall govern. In the event that discrepancies occur between the caliper size and the container size as indicated in the plant list and on the Drawings, the caliper size indicated on the Drawings and the minimum caliper size indicated in the APS Landscape Design Directives shall govern.

2.02 PLANT MATERIAL QUALITY

- A. Plant material quality, size and condition shall be in accordance with American Standard for Nursery Stock, 1980, as published by the Committee on Horticultural Standards of the American Association of Nurserymen, Inc., the Drawings and the following requirements:

1. All plants shall be typical for their species or variety. All plants shall have normal, well developed branches and vigorous root systems. They shall be sound, healthy, vigorous, free from defects, disfiguring knots, abrasions on the bark, sun scale injuries, plant diseases, insect eggs, borers, and all other forms of infections.
2. Unless otherwise stated on Drawings or approved by the Owner's Representative, all plants shall be nursery grown and shall be tagged with nursery labels indicating species and variety.
3. Container grown plant materials shall have been grown in its delivery container for not less than six (6) months, but not more than two (2) years. Any root bound material will not be accepted.
4. Balled and burlap plant materials shall have a solid ball of earth of minimum specified size and held in place securely by burlap and a stout twine or rope. Broken or loose balls will not be accepted.
5. Unless specifically noted on the Drawings, all trees shall have a single trunk that is straight and free of "dog legs", "crooks", "Y-crotches", or other disfiguring shapes. The central leader of all trees shall not have been pruned. Trees with double leaders are not acceptable.
6. All plant materials shall have a uniform shape around its complete circumference. Plant material with irregular branching patterns or with branching patterns more highly developed on one side than on other sides shall not be accepted.
7. The Owner's Representative shall inspect all plant material at the Contractor's yard or at a wholesale nursery of the Contractor's choice prior to delivery to the job site. All material shall then be inspected at the job site prior to planting and after planting.
8. The Owner's Representative shall be the judge of the quality and acceptability of all plant material. All rejected material shall be immediately removed from the site and replaced with acceptable material at no additional cost to the Owner.

2.03 PLANTING SOIL MIXTURE:

- A. Planting Soil Mixture to be a mixture of one part backfill amendment to three parts of existing soil.
The Backfill Amendment shall consist of:
 1. 70% by volume, organic compost. Compost to be screened to ½" minus, pH not to exceed 7.0 Electrical conductivity (EC) of compost not to exceed 3.5 nmhos/cm. Percentage of organic

matter shall be not less than 1% by weight. Carbon to nitrogen ratio of compost shall not exceed 50:1.

2. 20% by volume, "Moisture-lite" screened to pass a #40 mesh.
3. 10% by volume, "Ecolite" screened to pass a #40 mesh.
4. Components to be homogeneously mixed, in ten cubic yard batches to provide a uniform product, free from weed seeds, sticks rocks, or other deleterious material.
5. The backfill amendment shall be a produced by:
Growell
RR9, Box 862
2nd and Bates Rd., SW
Albuquerque, New Mexico 87105
(505) 877-8670
or equal.
6. Each Delivery shall have a load ticket. The load ticket shall list:
Source of Mixture
Approximate volume of load
Date of delivery or loading
Name of individual representing the source

Ticket shall be collected and provided to the Owner's Representative.

2.04 MULCH

- A. All landscape areas shall receive aggregate mulches type and size as specified on Drawings. All aggregate mulches shall be installed at a minimum depth of 2" and shall be installed over filter fabric. All crusher fine mulches shall be installed at a minimum depth of 3" and shall be installed over filter fabric unless otherwise, specifically directed by Owner's representative.

PART 3 EXECUTION

3.01 PLANTING OPERATIONS:

- A. Planting operations as specified herein shall begin only when the irrigation system has been installed and inspected, and other work including placing of topsoil to finished grade has progressed sufficiently to permit planting and shall be performed only during favorable weather conditions in accordance with accepted practice.

- B. In any one day, only those plant materials intended to be planted that day shall be delivered to the project site. Unless otherwise approved by the Owner's Representative, all plant materials shall be located where shown on the plan except when adjustments due to field conditions are required. The location of all trees and shrubs shall be staked by the Contractor before making any excavations, and locations shall be inspected by the Owner's representative prior to installation.

3.02 PLANTING:

- A. All planting and backfilling shall be performed in accordance with accepted nursery practice, the Drawings, and the following requirements:
 1. The contractor shall take care when backfilling planters to provide adequate compaction of the fill materials in order to prevent settling.
 2. Prepare all planting pits and install plants as shown on Drawings. Plants shall be set plumb and straight unless Drawings indicate otherwise.
 3. Backfill for planting pits shall consist of the specified Planting Soil Mixture. The plant shall be positioned in the hole, and backfilled. The backfilling shall be completed, and materials tamped. When pit is nearly filled, water thoroughly and allow water to soak away. If settling of backfill occurs after watering, add more backfill to bring to finish grade.
 4. After completion of planting, all trees shall be pruned at the direction of the Owner.

3.03 MULCHING;

- A. Mulching shall be completed as indicated on the Drawings.

3.04 MAINTENANCE AND PROTECTION:

- A. Maintenance and protection of trees, shrubs, and ground cover shall begin immediately following the last operation of installation for each plant and shall continue until the entire landscape project is accepted by the Owner. Maintenance shall include watering, weeding, cultivating, removal and replacement of dead plant material, removal of debris, resetting of trees to upright positions, restoration of earth basins, and such other operations as may be necessary for the health of the planted stock and the general appearance of the landscaped areas. Care shall include protection of planted stock from damages resulting from trespass, erosion (including watering), weather, vandalism, disease and other hazards.

3.05 GUARANTEE:

- A. All plant materials shall be guaranteed to be in a live, healthy, and normal growing condition following the date of final acceptance by the Owner's Representative through one twelve month growing season. Plant materials that are dead or in an unhealthy, impaired growth condition shall be removed and replaced by the Contractor as directed by the Owner's Representative at no additional cost to the Owner. Replacement material shall be of equal quality, size, and species as that which is being replaced and shall be approved by the Owner's representative prior to planting. Any plants replaced after the first six months of the guarantee period shall also be under warranty for six months after the replanting date.

3.06 INSPECTIONS:

- A. The following inspections shall be the minimum required inspections during the course of construction. Additional inspections shall be made at any time at the discretion of the Owner's Representative.
- B. It shall be the responsibility of the Contractor to notify the Owner's representative, 48 hours in advance of each required inspection.
- C. The sequence of required inspections shall not be changed from the sequence listed below. The Contractor shall not proceed with the work of the next sequence without written approval of the work of the previous sequence.
 - 1. Inspect plant material at Contractor's yard or Nursery prior to delivery to job site.
 - 2. Inspect staked locations of materials prior to planting.
 - 3. Inspect material at the job site prior to and during planting.
 - 4. Inspect the planting depth of Trees
 - 5. Inspect at the time of final acceptance by the Owner.
 - 6. Inspect 6 months after final completion.
 - 7. Inspect 12 months after final completion.

END OF SECTION 32 93 00

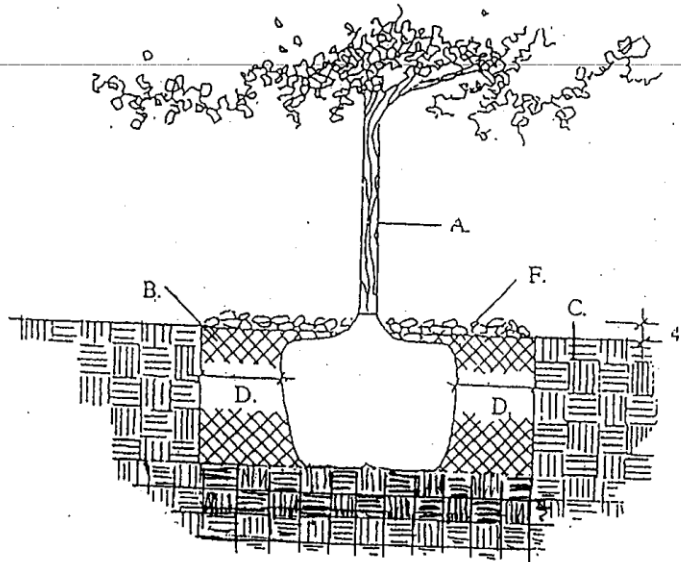

GENERAL NOTES

1. Stabilize soil below rootball prior to planting to prevent tree from settling.
2. Top of rootball indicates level at which tree was grown and dug; this represents the level at which the tree should be installed; that level may be exceeded by only one inch layer of soil.
3. Prior to backfilling tree, all wire, rope and synthetic materials shall be removed from the tree and the planting pit.
4. Prior to backfilling, remove wire basket and all burlap shall be cut away from the rootball.

CONSTRUCTION NOTES

- A. Tree
- B. Planting soil mixture (see specifications)
- C. Finish grade
- D. Space between the rootball and the planting pit to be equal to the diameter of the rootball.
- E. Loosen soil to a depth of 6"
- F. 2" minimum depth aggregate mulch per drawings over filter fabric



ISOLATED TREE PLANTING



ALBUQUERQUE PUBLIC SCHOOLS
JANUARY 2008

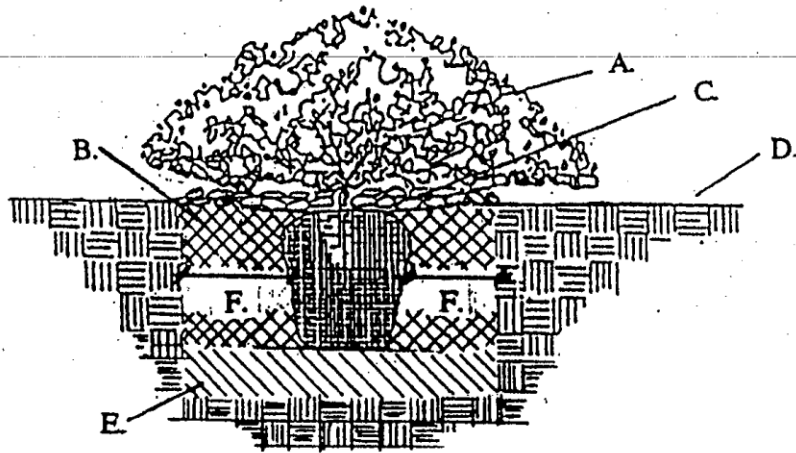

CONSTRUCTION NOTES

- A. Shrub
- B. Planting soil mixture (see specifications)
- C. 2" Depth minimum aggregate mulch per plans over filter fabric
- D. Finish grade
- E. Loosen soil to a depth of 6"
- F. Space between the rootball and the planting pit to be equal to the diameter of the rootball.



ISOLATED SHRUB PLANTING



ALBUQUERQUE PUBLIC SCHOOLS
JANUARY 2008

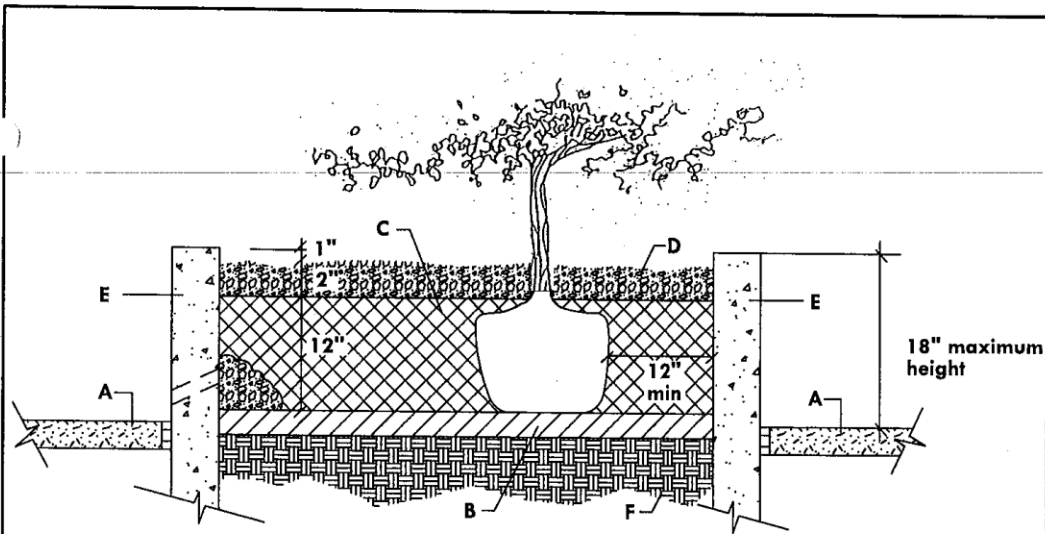

GENERAL NOTES

1. Existing soil within the shrub planter shall be renewed and replaced with the specified planting soil mixture.
2. Stabilize soil below rootball prior to planting to prevent tree from settling.
3. Top of rootball indicates level at which tree was grown and dug; this represents the level at which the tree should be installed; that level may be exceeded by only one inch layer of soil.
4. Prior to backfilling tree, all wire, rope, and synthetic materials shall be removed from the tree and the planting pit.
5. Prior to backfilling, remove wire basket and all burlap shall be cut away from the rootball.
6. Minimum planter size for trees shall be 10'x10'.

CONSTRUCTION NOTES

- A. Materials varies (reference the drawings).
- B. Loosen soil to depth of 6".
- C. Planting soil mixture (see specifications). If planter is larger than 10'x10', provide planting soil mixture at a rate of 10'x10' per each tree and 3'x3' per each shrub. Areas between trees and shrubs can be filled with native soil free of rocks 2" diameter and larger, and all debris shall be removed.
- D. Mulch per drawings (2" depth minimum) over filter fabric
- E. Wall per drawings
- G. 1" diameter pvc weep holes with gravel mulch per drawings.

RAISED PLANTERS FOR TREES & SHRUBS



ALBUQUERQUE PUBLIC SCHOOLS
JANUARY 2008

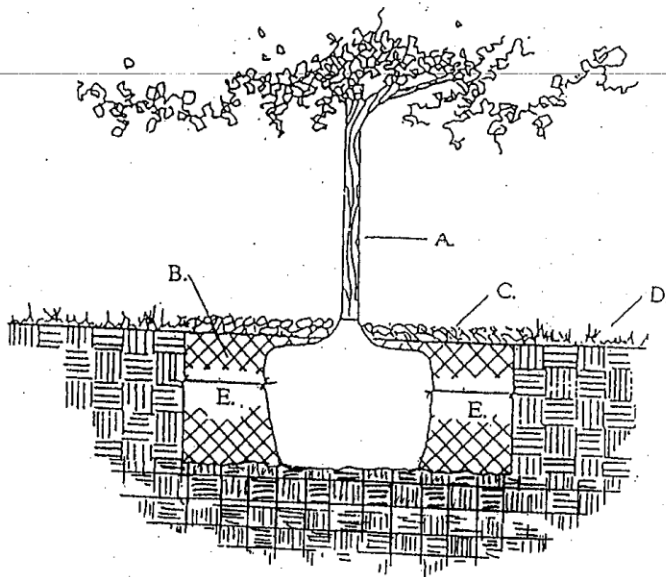

GENERAL NOTES

1. Stabilize soil below rootball prior to planting to prevent tree from settling.
2. Top of rootball indicates level at which tree was grown and dug; this represents the level at which the tree should be installed; that level may be exceeded by only one inch layer of soil.
3. Prior to backfilling tree, all wire, rope and synthetic materials shall be removed from the tree and the planting pit.
4. Prior to backfilling, remove wire basket and all burlap shall be cut away from the rootball.

CONSTRUCTION NOTES

- A. Tree
- B. Planting soil mixture (see specifications)
- C. 4" Depth of bark mulch (no filter fabric)
- D. Turf at finish grade
- E. Space between the rootball and the planting pit to be equal to the diameter of the rootball.
- F. Loosen soil to a depth of 6"



TREE PLANTED IN TURF



ALBUQUERQUE PUBLIC SCHOOLS
JANUARY 2008

January 2008
APS Site Committee
Playgrounds

Notes from meeting with Rick Leydig and Filo, APS Maintenance & Operations Playgrounds.

General Comments:

- Current APS Playground Standards are out of date.
- Need to Notify All APS Schools regarding playground standards – what can and what can't be done.
- Drawings for all Playground Projects on APS Properties must be reviewed and approved by the APS M&O Playground Department prior to ordering equipment and installation.
- All Playground equipment shall be installed by the APS On-Call Contractor. APS On-Call Contractor shall be IPEMA Certified.
- All Playground equipment has to be IPEMA Certified.

Specific Comments:

- Any kind of modifications to existing playgrounds will require that surfacing, access, etc. be brought to current ADA requirements for playground accessibility.
- Any kind of modifications to existing playgrounds will require the following:
 1. All existing playground equipment must be audited (Audit to be paid for by the playground designer).
 2. All non-compliant equipment must be removed and replaced as part of any playground project on an existing school.
- Access for maintenance (New & Existing Playgrounds) Minimum opening of 7'-0" clear for installation of equipment and maintenance.
- Minimum clear access of 7'-0" clear between playground walls and other items for tractor access. Example: playground containment walls and raised planter walls.
- All APS playgrounds are required to have engineered wood fiber mulch installed as a safety surfacing. Sand is no longer allowed as a safety surfacing. Separate sand play areas are allowed.
- Surfaces adjacent to play areas must be paved or treated to control erosion and for ease of maintenance.
- New Playground Designs: no utilities are allowed to cross through play areas. (No water, sanitary sewer, electrical, gas, communications cables, etc.)

- Absolutely no site drainage or roof drainage is allowed to enter playground or play equipment containment areas. Play equipment can not be installed within ponding areas.
- All new playgrounds and new equipment installed within existing playgrounds shall have an age appropriate sign installed with equipment.
- Pre-K play areas shall have an age appropriate tot lot that is totally fenced off to separate tot lot from the other play areas.
- All new permanent playground equipment must be installed within concrete borders with ADA access.
- At all new play structures at least ½ of the play activity must be at ground level and shall be ADA accessible.
- ADA Accessibility shall comply with the most current publication Current Guide to ADA Accessibility Guidelines for Play Areas as published by Architectural & Transportation Barriers Compliance Board.
- New playground designs and remodel designs of existing playgrounds shall include 2 – 3 trash receptacles.
- A minimum asphalt paved area of 7'-0" width shall be installed around all concrete containment areas.
- Swings: if a single post type is specified – Clamp type only to be used (no insert type)
- Final Walkthrough Meetings for Playgrounds should include a meeting with key school personnel. Meeting should include information on how the school can conduct a team inspection meeting and discuss how the play equipment and play equipment is to be used.
- A playground audit shall be required for all new playgrounds. Audit shall be paid for and provided by the play equipment installation contractor. And shall be part of the final project close out projects.

Albuquerque Public Schools

Fencing Design Directives

The placement of fencing and gates is an important part of the site design for any school because they are used to help to secure a site, and help in directing pedestrian and vehicular traffic. They are also used to define a space, create a barrier on high walls or at retention/detention ponds, etc. The following guidelines should be used when specifying and installing fencing on all APS District Properties.

General Fencing Directives

- All fencing on Elementary Schools chainlink fencing shall be knuckle on knuckle. In cases where knuckle on knuckle is not available (for example 6' ht fencing), the fabric shall be placed so that the knuckles are on the bottom of the fencing.
- All fencing shall have a top and bottom rail
- Whenever possible all bolts and fasteners shall be placed so that the end pieces project away from play areas, walkways, etc. and all bolts and fasteners shall be cut to flush with bolts, etc. so that there are no protruding ends.

Albuquerque Public Schools Drainage Design Directives

General Drainage Directives in Landscape/Planting areas

- All roof drains shall have a paved swale extending from the point where the roof drain exists to a point where it exits the landscaped area. These swales shall be paved with either concrete, or rip-rap that is embedded in cement. No loose cobble swales shall be allowed on APS District Properties.
- All drainage swales that pass through a landscape/planting area shall be paved with either concrete, or rip-rap that is embedded in cement. No loose cobble swales shall be allowed on APS District Properties. The paved swale shall extend from the point where it exits the landscape area.
- Water harvesting in landscape areas is encouraged. The depressions for harvesting must be shallow enough to drain quickly upon a storm event and shall not hold water for more than 5,760 minutes or 96 hours.
- Sidewalk culverts shall not be used on APS District Properties.
- When ever a drainage drop inlet occurs in either a landscape area or future landscape area (bare dirt area) there shall be an apron of cemented rip-rap placed around the entire drop inlet. This rip-rap apron shall be at least 18” wide. This rip-rap apron is in addition to the standard concrete apron and will not be substituted for the standard concrete apron.

ONE CALL METHOD – CONTRACTOR PROCEDURES FOR APS/FDC
UTILITY LINE SPOTTING
To be used after 7/11/07

Contractor Responsibilities:

1. Submit complete electronic (email) request for line spotting a minimum of three working days (72 hours; all time references herein exclude weekends and State holidays) in advance of the planned sub-surface disturbance (including, but not limited to, excavation, trenching, boring, probing or drilling) to New Mexico One-Call, phone 811. The request must include the following:
 - Individual responsible (Requestor) and company name, email address and phone and fax contact information of the requesting excavator;
 - The associated APS project number APS facility or school name and brief description and the purpose of the type of work to be done.
 - Name and email of the APS Construction Manager.
 - Whether or not the excavation site is pre-marked in white. (Highly advised)
 - An accurate physical description and address of the location and size of the excavation site to be line spotted at this time.
 - Driving instructions if outside Metropolitan Albuquerque.
 - Spotting instructions;
 - Any appropriate remarks regarding access to or hazards at the site;
2. Have a representative available if needed on site to assist line spotters in designation of line spotting area(s) and clarify any instructions upon request from line spotters.
3. Line spots are good for 10 working days and must be refreshed by the excavation contractor as needed using the same American Public Works Association colors;
4. Do not proceed with any sub-surface disturbance until Requestor receives and records verbal (phone) and/or electronic (email) close-out notice from Abasto Utility Location Co. (AULC) and utility companies as applicable.

Processing:

5. AULC will email and voice notify by phone the close-out notice by reference ticket number that AULC has completed line-spotting of APS owned utility lines to Requestor within 72 hours of receiving the complete request via email, including associated remarks and/or field notes.

Albuquerque Public Schools – September 2007		
Irrigation Pressure Test Form Main, Wire & RCV		Page 1 of ____
Date of Testing:		
Construction Company Name:		
Project Name:		
School Name:		
School Address:		
Mainline Test		
	Start Time	End Time
Visual Inspection Notes:		
	Pressure	Pressure
Backflow Device Inspection		
Type of Device:		
Model No.:		
Hot Box No.:		
Heat Tape Installed?	Yes	No
Heat Tape Plugged In?	Yes	No
RP Test Form Turned In?	Yes	No
Visual Inspection Notes:		
Flow Meter Inspection		
Type of Device:		
Model No.:		
Communication Cable installed?	Yes	No
Read Switch Test Performed?	Yes	No
Installed w/ flow in correct direction?	Yes	No
Visual Inspection Notes:		
24 Volt Wire Inspection		
Visual Inspection Notes:		
APS Representative		Date
Contractor Representative		Date

Albuquerque Public Schools – September 2007	
Irrigation Pressure Test Form Main, Wire & RCV	Page 2 of _____
Remote Control Valve Inspection – Valve #	
Visual Inspection Notes:	
Remote Control Valve Inspection – Valve #	
Visual Inspection Notes:	
Remote Control Valve Inspection – Valve #	
Visual Inspection Notes:	
Remote Control Valve Inspection – Valve #	
Visual Inspection Notes:	
Remote Control Valve Inspection – Valve #	
Visual Inspection Notes:	
Remote Control Valve Inspection – Valve #	
Visual Inspection Notes:	
Remote Control Valve Inspection – Valve #	
Visual Inspection Notes:	
APS Representative	Date
Contractor Representative	Date

